

Scivolo accompagnamento pezzi

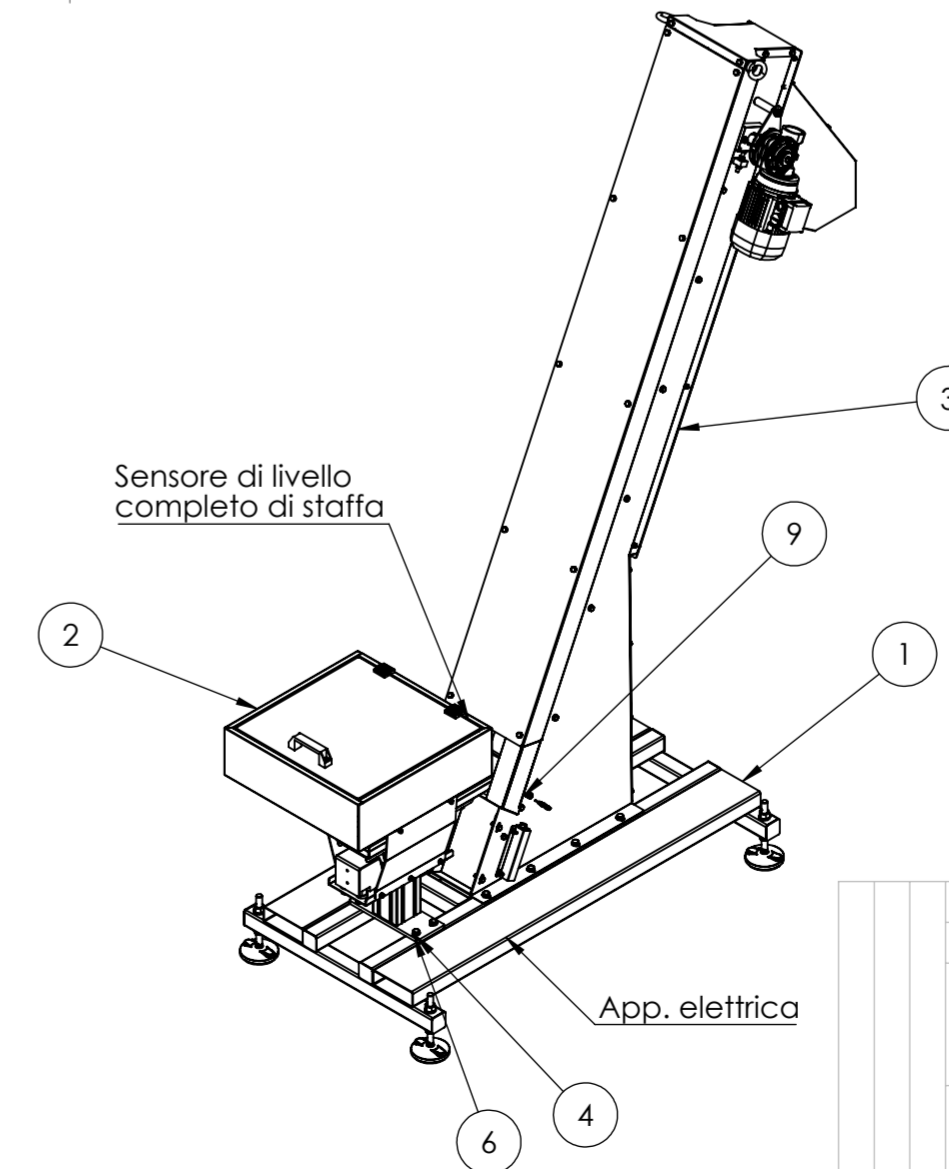
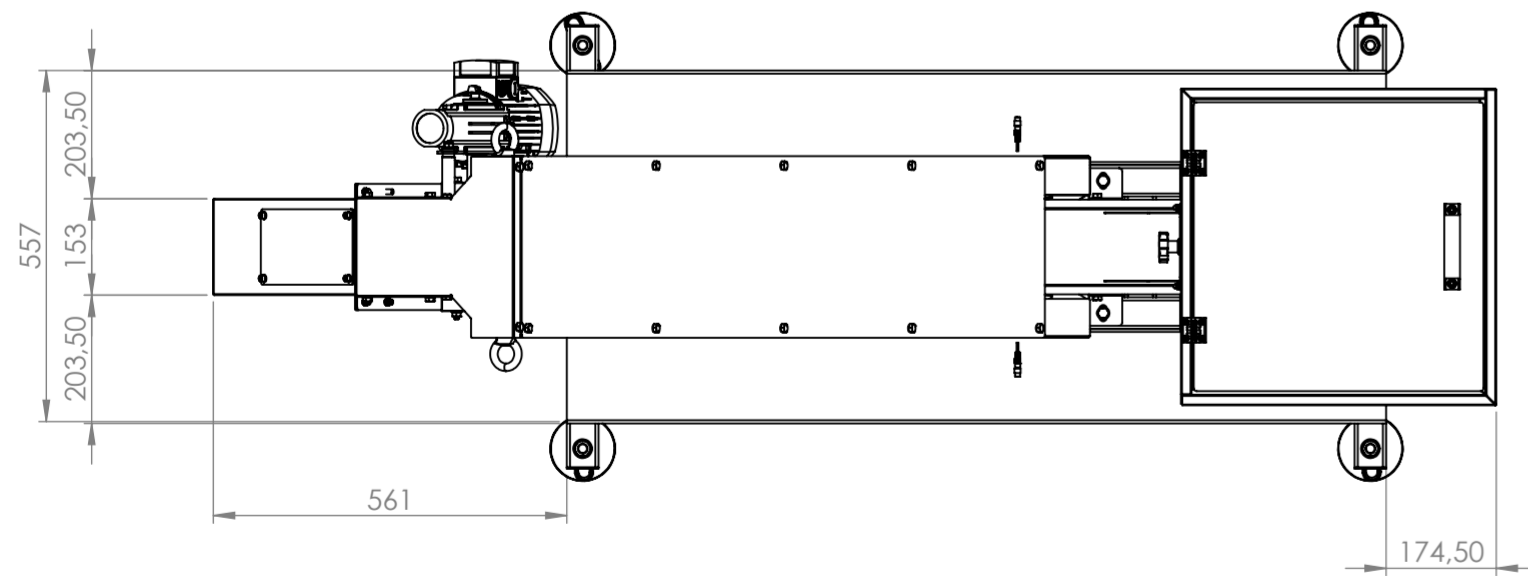
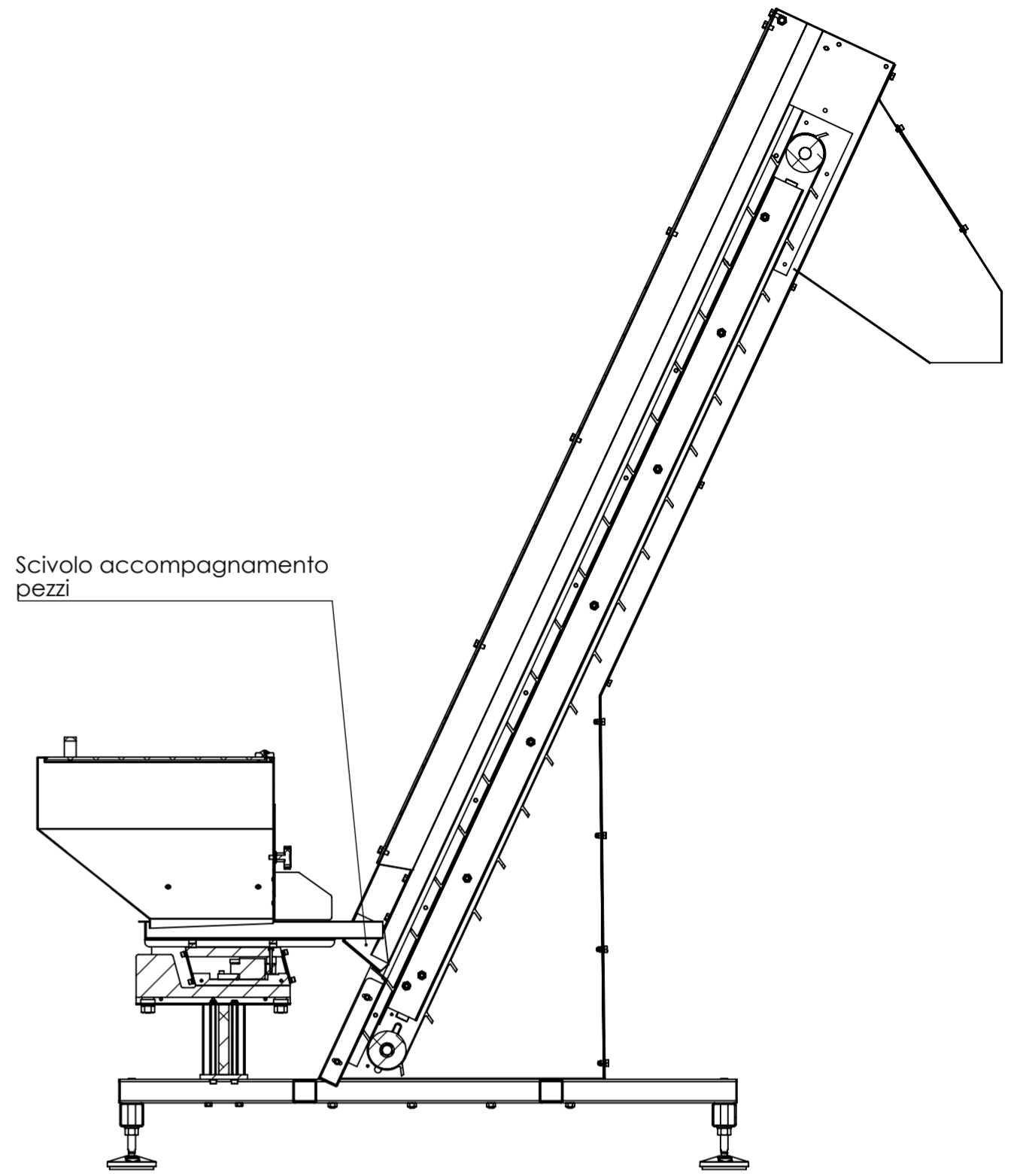

SEZIONE B-B

tolleranze generali ±0.1mm

Pos.	Q.ta'	Denominazione	Materiale	Trattam.	UNI / note
		<b>DECA</b> S.r.l. VIBROALIMENTATORI ELEVATORI	Via XXV Aprile, 2 23804 Monte Marengo (LC) Tel. 0341/632080 Fax 0341/608154 E-mail: info@decasrl.biz		Scala 1:12 Disegnato da Data
OGGETTO:					 sistema E UNI 3970
Elevatore con tramoggia 50Lt					DISEGNO N° 0855-21219-000.02